



FIRE DAMPERS

FIRE DAMPER FOR DYNAMIC SYSTEMS - FDC/FDCA MODELS - SINGLE SECTIONS

FDC 100% FREE AREA



FDCA NOT 100% FREE AREA





FIRE DAMPER FOR DYNAMIC SYSTEMS - FDC/FDCA MODELS - SINGLE SECTIONS

FEATURES:

- UL classified for dynamic systems in accordance with UL 555 & NFPA 90A
- Civil Defence Approved
- Fusible link set at 165° F
- Fire rated for 1 ½ hour
- Mounting type: vertical
- Flow rating is 2000 cfm / ft²
- Static pressure is 4 in.wc

MAXIMUM UL CLASSIFIED SIZES (OUT TO OUT)		
section	MAXIMUM WIDTH (")	MAXIMUM HEIGHT (")
SINGLE	36	36

CONSTRUCTION

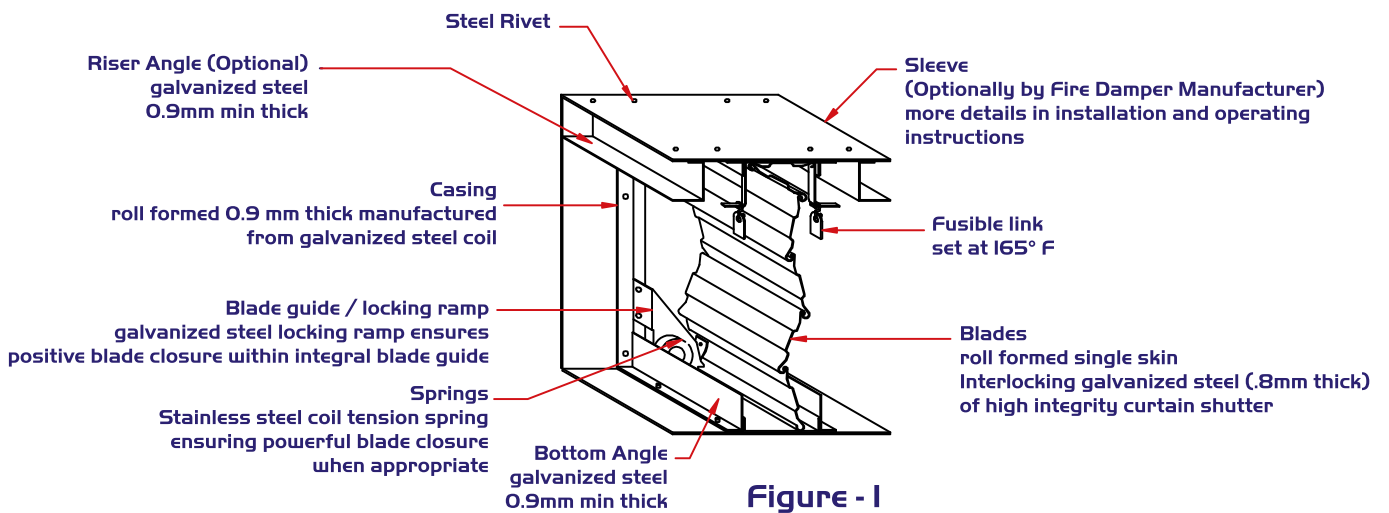
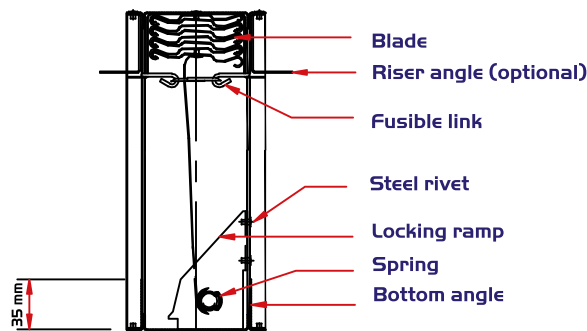

Figure - 1



Cross sectional view single section

Figure - 2





INSTALLATION AND OPERATING INSTRUCTIONS

1. The damper ① should be installed centrally within the surrounding masonry / gypsum floor or wall ⑦
2. The damper ① should be installed in a rectangular galvanized steel ② (optionally by Fire Damper Manufacturer) with a minimum thickness of 0.9mm. this sleeve should be attached to the damper not to the builder's work using steel rivets ⑤ 4.8mm dia. and spaced at not more than 225mm centers and 13 mm from corners (1/2")
3. The damper is suitable only for rectangular space and can not be use for annular space.
4. Allowance for expansion between sleeve and builders work in both horizontal and vertical planes to be 3mm per 305 mm of length and width.
5. The sleeve ② (optionally by Fire Damper Manufacturer) should be of suitable length to extend through the wall to enable the fitting of the cover angles and ductwork.
Minimum of 90 mm and maximum 152 mm beyond the floor or wall / include thicknesses of sleeve in table I.

Sleeve Thickness (mm)
0.9
1.2
1.5
2

TABLE I

6. The mounting angles ③ should be attached to the sleeve (optionally by Fire Damper Manufacturer) by 8mm dia ④ bolts at a maximum of 225mm centers, and should form a complete frame around the sleeve and cover over the expansion gap ⑥ required between sleeve and wall / floor opening. The four corners of the mounting angles are not to be welded. The bolts connecting the mounting angles to the sleeve to be 102 mm maximum from the corners Mounting angles will be send in loose parts.
7. The mounting angles ③ should be of such a size as always to form an overlap with the wall / floor by 25 mm minimum and should be manufactured from a minimum size of 35 x 35 x 2.5 mm GI angle.
8. A fusible link is UL tested, Elsie brand, set at 165° F
9. The duct-sleeve connection to be of as per what shown in (figure4) page 13.
Connecting ducts shall not be continuous and shall terminate at the sleeve.
Installation shall comply with NFPA 90A
10. All fixing of frames must be positioned clear of the damper blade path so as not to impede proper closure.

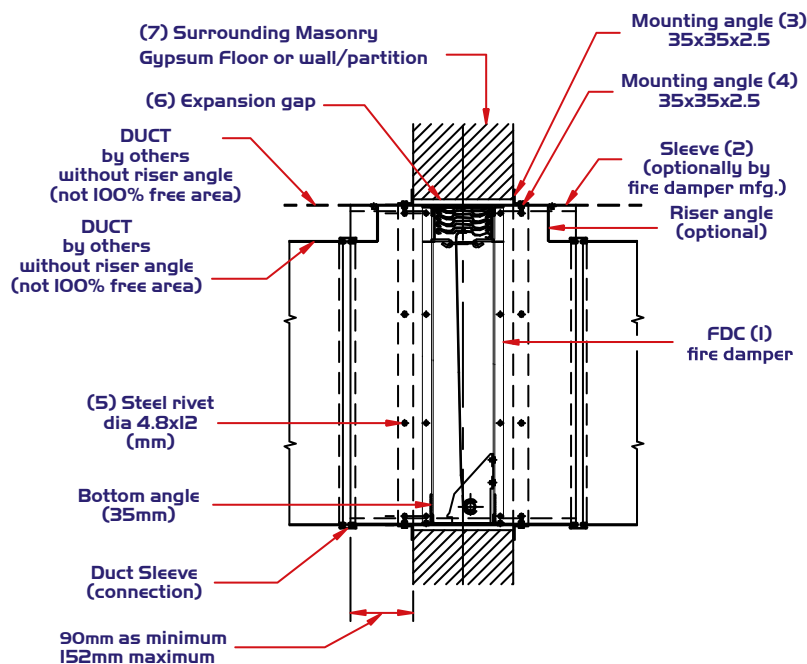

Figure 3 (CROSS SECTION DETAILS)
SINGLE SECTION FDC FIX TO WALL





DUCT - SLEEVE CONNECTIONS

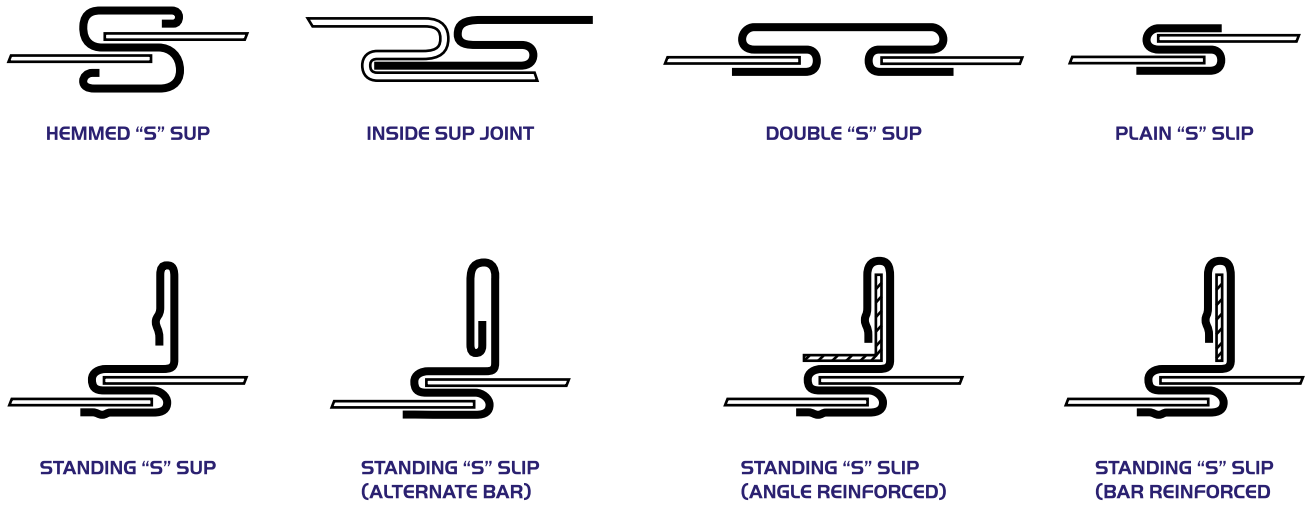

Figure - 4

EXPLODED ASSEMBLY FOR FDC TYPE WITH SLEEVE

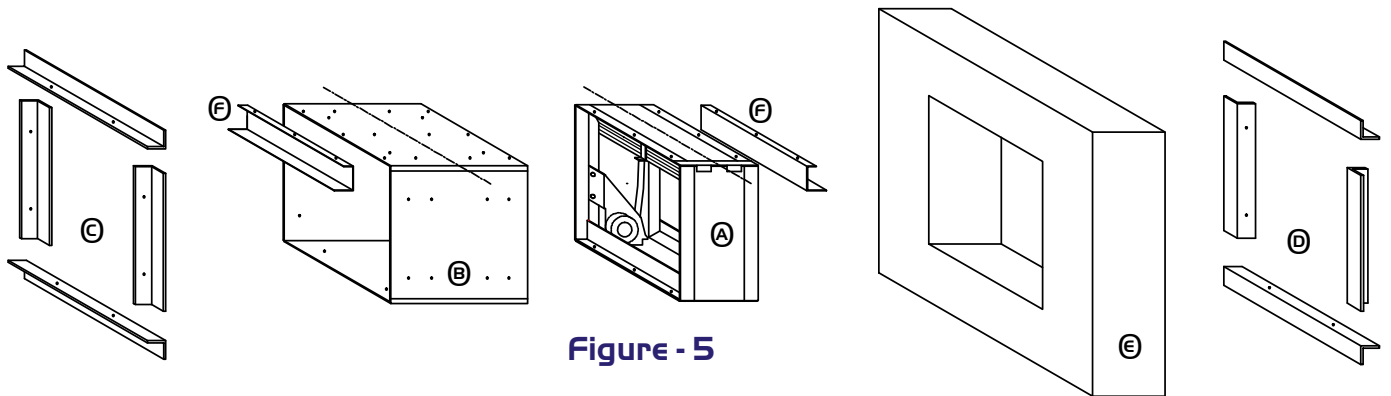

Figure - 5

ASSEMBLY PROCEDURES:

1. Fix the damper (A) into the sleeve (B) matching their center axis and hole provision using steel rivet.
2. If the riser angle (optional) is use then, fix the riser angle (F) (optional) into the fire damper sleeve matching their hole provision using steel rivet. If not go to step no.3.
3. Fix the fire damper with sleeve into the concrete / gypsum wall (E) opening by a front mounting angle (C) 35x35 matching their hole provision using M8 Hex bolt and nut. Opening size should have clearance of 3 mm per 305 mm of length and width.
4. Finally when the Fire Damper with sleeve is already fitted to the wall, fix the back mounting angle (D) 35 x 35 matching their hole provision using M8 Hex bolt and nut.





FIRE DAMPERS

ORDERING SYSTEM

FDC 100% FREE AREA

SIZES RANGE		
	(mm)	(inches)
H	80 - 825	3.2" - 32.5"
W	100 - 915	4" - 36"

X (mm)	H (mm)
25	80 - 150
50	151 - 450
75	451 - 650
90	651 - 825

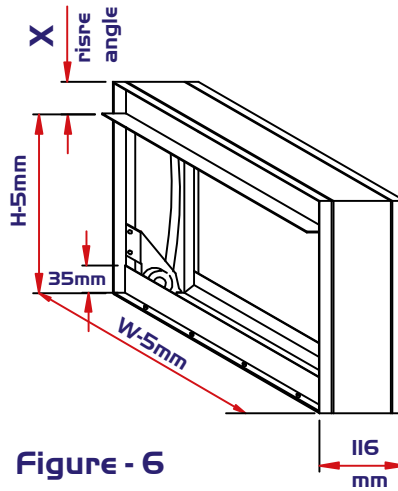

Figure - 6

FDCA NOT 100% FREE AREA

SIZES RANGE		
	(mm)	(inches)
H	100 - 915	4" - 36"
W	100 - 915	4" - 36"

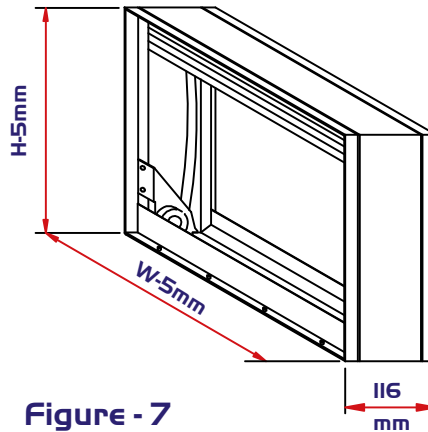

Figure - 7



Ordering Key:

DYNAMIC	F	D	C	A	W	X	H	S	L	V	C	O	9
FIRE DAMPER FOR VERTICAL MOUNTING FOR DYNAMIC APPLICATIONS													
- : 100% FREE AREA (STANDARD)													
A : NOT 100% FREE AREA													
SIZE: WIDTH X HEIGHT													
UP TO 36"X36" OUT-TO-OUT DIMENSIONS FOR SINGLE SECTION,													
- : WITHOUT SLEEVE (STANDARD)													
SLVC09 : WITH 0.9 MM THICK G.I. SLEEVE													
SLVC12 : WITH 1.2 MM THICK G.I. SLEEVE													
SLVC15 : WITH 1.5 MM THICK G.I. SLEEVE													
SLVC20 : WITH 2.0 MM THICK G.I. SLEEVE													

