



# MULTI-BLADE UL CLASSIFIED STATIC FIRE DAMPER MODEL BFD (3 HR) / MODEL BEFD (1½ HR)

## STANDARD CONSTRUCTION

**Standards:** Designed and tested in accordance with UL555 for STATIC applications. Meets NFPA 90A and SMACNA requirements for fire dampers.

**Application:** For fire barriers in STATIC applications.

**Frame:** 133mm Roll formed hat-shaped made of 1.4mm thick galvanized steel with reinforced corners, having integral bracing and 90° perpendicular overlap at a corner.

**Blades:** Roll formed 3 V-shaped made of 1.4mm thick galvanized steel.

**Bushes:** Bronze bushes.

**Axes:** 3/8" Square axles made of galvanized steel.

**Linkage:** Mechanical and concealed in frame.

**Jamb Seals:** Stainless steel jamb seals.

**Drive Mechanism:** 1/2" Round Jack Shaft made of galvanized steel.

**Fusible link:** UL Listed 165° F.

**Sleeve:** Sleeve made of 400mm depth and 1.1mm thickness galvanized steel.

**Mounting:** Vertical mounting.

**Fire Rating:** 3 hr (Model BFD)

**Quadrant:** Manual locking quadrant made of galvanized steel (becomes option for motorized models).

**Sizes:** Single Section: Max. 36" X 36"  
Multiple Section: Max. 72" X 72"



Models BMFD-TF, BMFDLT-TF, BEMFD-TF & BEMFDLT-TF



Models BMFD/R, BMFDLT/R, BEMFD/R & BEMFDLT/R

Reducer on sleeve used when damper sizes are requested below 200x200mm

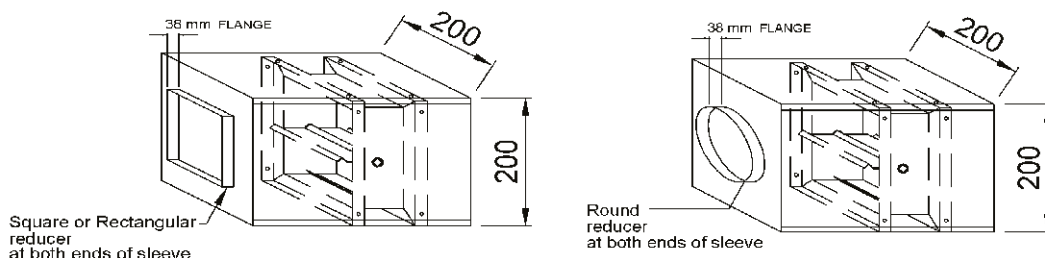





# MULTI-BLADE UL CLASSIFIED STATIC FIRE DAMPER MODEL BFD (3 HR) / MODEL BEFD (1½ HR)

## ASSEMBLY

### Single section assembly up to 36" X36" (915X915mm)

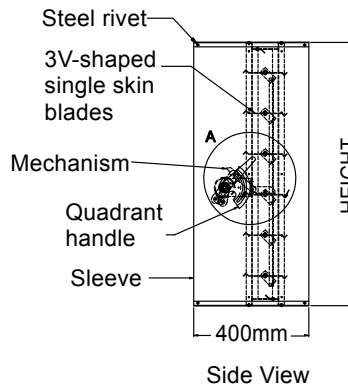
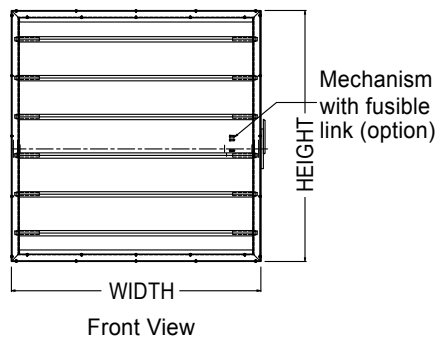
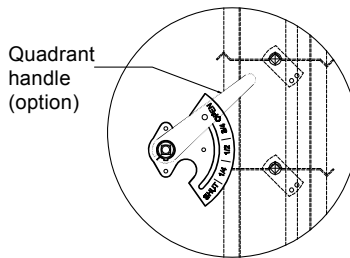
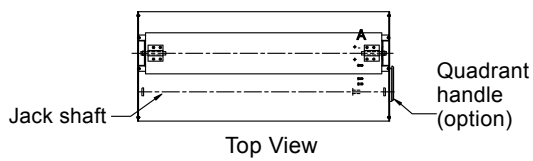

### Multiple section assembly up to 72" X72" (1830X1830mm)

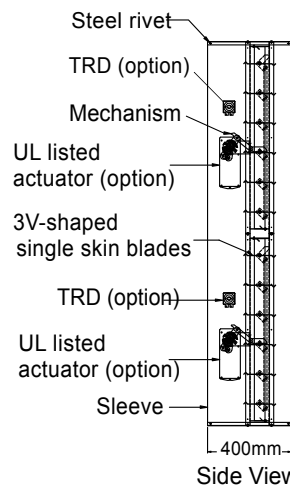
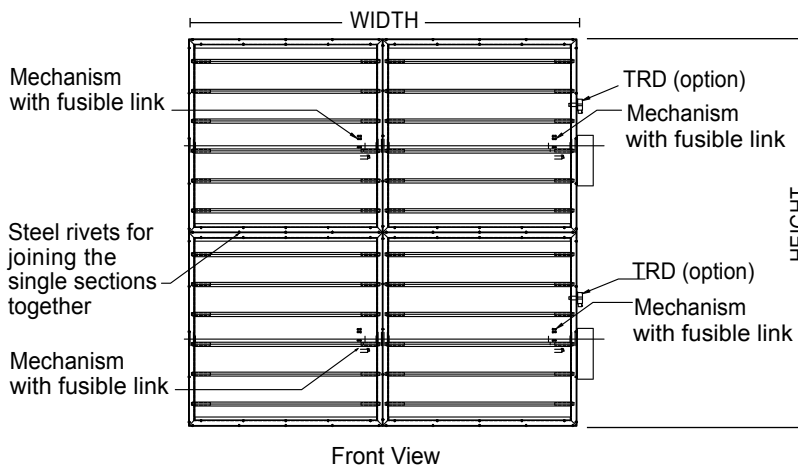
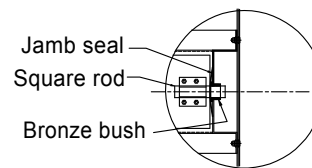
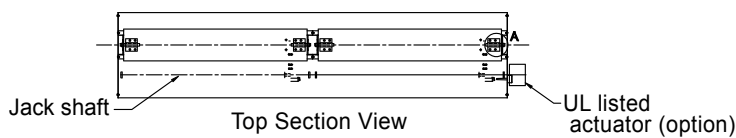



# MULTI-BLADE UL CLASSIFIED STATIC FIRE DAMPER MODEL BFD (3 HR) / MODEL BEFD (1½ HR)

## PERFORMANCE DATA

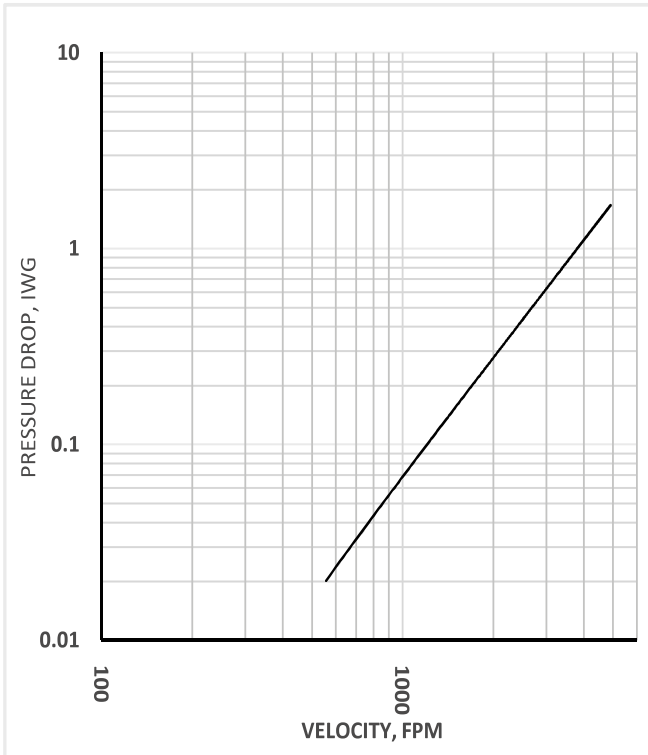

*Note:*  
Pressure drop test was done at an independent laboratory in accordance with the AMCA 500-D standard on 36"X36" sample.



## ORDERING KEY

STATIC	B	FD	/R8	-F165	SIZE	XS
-FOR STATIC SYSTEMS						
B: 3 HRS RATED BE: 1½ HRS RATED						
FD: MULTI-BLADES FIRE DAMPER - NOT MOTORIZED MFD: MOTORIZED MULTI-BLADES FIRE DAMPER						
--: WITHOUT ROUND SPIGOT /Rd: WITH ROUND SPIGOTS OF "d" DIA. ("d" IS DIAMETER IN INCH UP TO 32")						
-F165: WITH 165°F FUSIBLE LINK -F212: WITH 212°F FUSIBLE LINK -T: WITH 165°F RESETTABLE THERMOELECTRIC TRD -TF: WITH 165°F RESETTABLE THERMOELECTRIC TRD AND 212°F FUSIBLE LINK						
SIZE: WIDTH X HEIGHT -: WITH SLEEVE (STANDARD) XS: WITHOUT SLEEVE						





# MULTI-BLADE UL CLASSIFIED STATIC FIRE DAMPER MODEL BFD (3 HR) / MODEL BEFD (1½ HR)

## INSTALLATION

(A)

### INSTALLATION AND OPERATING INSTRUCTIONS FOR MODELS BMFD-F, BMFDLT-F, BMFD/R-F, BMFDLT/R-F, BEMFD-F, BEMFDLT-F, BEMFD/R-F & BEMFDLT/R-F

- 1) The damper (1) should be installed vertical, centrally and resting on the bottom opening within the surrounding masonry / gypsum wall (7). Actuator should be out of wall / gypsum partition as shown in (figure 1).
- 2) The damper (1) should be installed in a rectangular galvanized steel sleeve (2) with a minimum thickness of 1.1mm. This sleeve should be attached to the damper using M6 bolts (5) and spaced at not more than 110 mm centers and 30 mm from corners.
- 3) Clearance requirements for damper sleeves within a wall opening are based on 1/8 inch per foot ( 10 mm per meter) of width or height unless otherwise stated in the listing of the assembly.
- 4) The sleeve (2) should be of suitable length to extend through the wall to enable the fitting of the cover angles and ductwork. Minimum of 90mm from the wall and total depth of the sleeve should not exceed more than 510mm.
- 5) The retaining angles (3) should be attached to the sleeve by 6 mm dia (4) bolts at a maximum of 110 mm centers, and should form a complete frame around the sleeve and cover over the expansion space (6) required between sleeve and wall opening. The four corner of the retaining angles are not to be welded. The bolts connecting the retaining angles to the sleeve to be 30 mm maximum from the corners. Retaining angles will be send in loose parts. Note: The retaining angles bolts should be out of the area of the damper frame.
- 6) The retaining angles (3) should be of such a size as always to form an overlap with the wall by 25mm minimum and should be manufactured from a minimum size of 35 x 35 x 1.5mm GI.
- 7) A fusible link –Elsle model-E rated at 165°F or 212°F used.
- 8) The duct sleeve connection to be of as per listed in UL 555. Connecting ducts shall not be continuous and shall terminate at the sleeve. Installation shall comply with NFPA 90A.
- 9) All fixing of frames must be positioned clear of the damper blade path so as not to Impede proper closure.

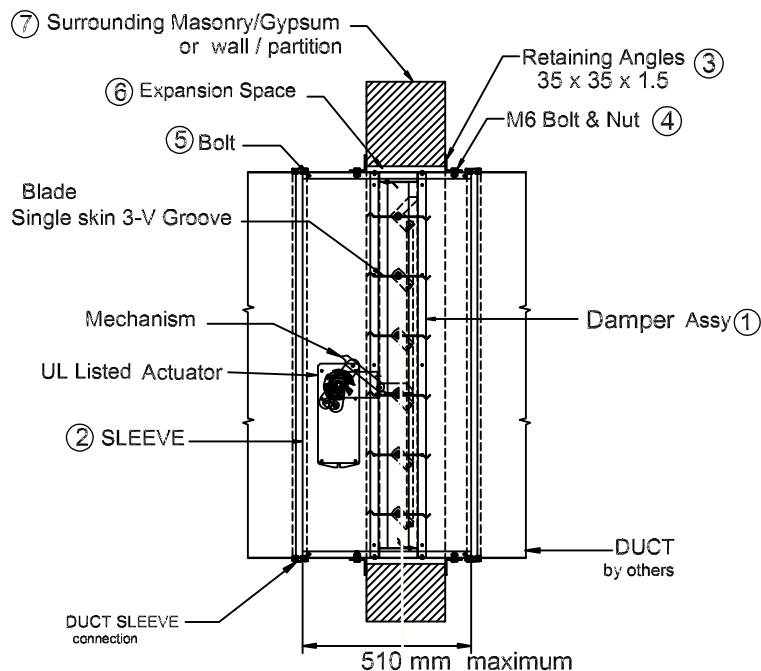

FIGURE 1





## MULTI-BLADE UL CLASSIFIED STATIC FIRE DAMPER MODEL BFD (3 HR) / MODEL BEFD (1½ HR)

### INSTALLATION

(B)

### INSTALLATION AND OPERATING INSTRUCTIONS FOR MODELS BMFD-T, BMFDLT-T, BMFD/R-T, BMFDLT/R-T BEMFD-T, BEMFDLT-T, BEMFD/R-T & BEMFDLT/R-T

- 1) The damper (1) should be installed vertical, centrally and resting on the bottom opening within the surrounding masonry / gypsum wall (7). Actuator should be out of wall / gypsum partition as shown in (figure 2).
- 2) The damper (1) should be installed in a rectangular galvanized steel sleeve (2) with a minimum thickness of 1.1mm. This sleeve should be attached to the damper using M6 bolts (5) and spaced at not more than 110 mm centers and 30 mm from corners.
- 3) Clearance requirements for damper sleeves within a wall opening are based on 1/8 inch per foot ( 10 mm per meter) of width or height unless otherwise stated in the listing of the assembly.
- 4) The sleeve (2) should be of suitable length to extend through the wall to enable the fitting of the cover angles and ductwork. Minimum of 90mm from the wall and total depth of the sleeve should not exceed more than 510mm.
- 5) The retaining angles (3) should be attached to the sleeve by 6 mm dia (4) bolts at a maximum of 110 mm centers, and should form a complete frame around the sleeve and cover over the expansion space (6) required between sleeve and wall opening. The four corner of the retaining angles are not to be welded. The bolts connecting the retaining angles to the sleeve to be 30 mm maximum from the corners. Retaining angles will be send in loose parts. Note: The retaining angles bolts should be out of the area of the damper frame.
- 6) The retaining angles (3) should be of such a size as always to form an overlap with the wall by 25mm minimum and should be manufactured from a minimum size of 35 x 35 x 1.5mm GI.
- 7) Push the re-set button to reset the TRD 165°F.
- 8) The duct sleeve connection to be of as per listed in UL 555. Connecting ducts shall not be continuous and shall terminate at the sleeve. Installation shall comply with NFPA 90A.
- 9) All fixing of frames must be positioned clear of the damper blade path so as not to impede proper closure.

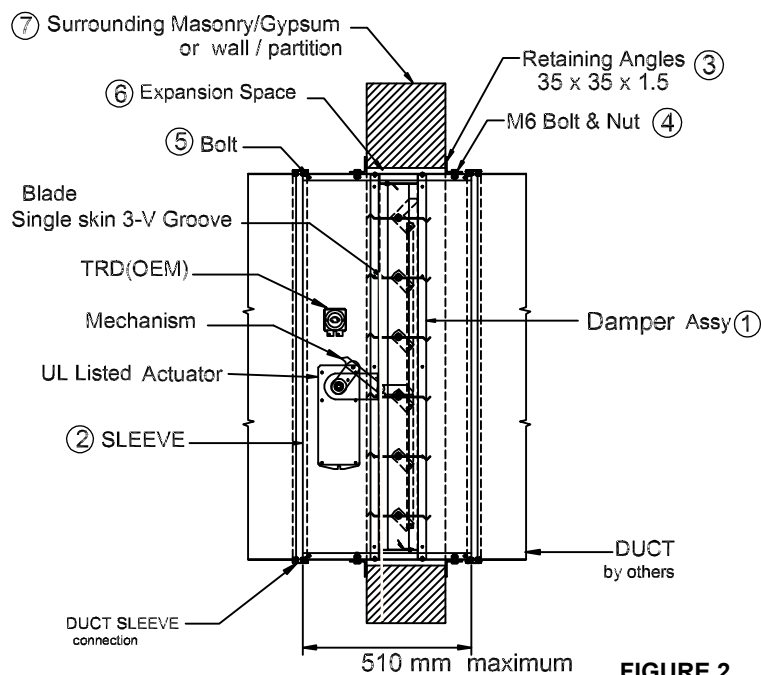

FIGURE 2





## MULTI-BLADE UL CLASSIFIED STATIC FIRE DAMPER MODEL BFD (3 HR) / MODEL BEFD (1½ HR)

### INSTALLATION

(C)

#### INSTALLATION AND OPERATING INSTRUCTIONS FOR MODELS BMFD-TF, BMFDLT-TF, BMFD/R-TF, BMFDLT/R-TF BEMFD-TF, BEMFDLT-TF, BEMFD/R-TF & BEMFDLT/R-TF

- 1) The damper (1) should be installed vertical, centrally and resting on the bottom opening within the surrounding masonry / gypsum wall (7). Actuator should be out of wall / gypsum partition as shown in (figure 3).
- 2) The damper (1) should be installed in a rectangular galvanized steel sleeve (2) with a minimum thickness of 1.1mm. This sleeve should be attached to the damper using M6 bolts (5) and spaced at not more than 110 mm centers and 30 mm from corners.
- 3) Clearance requirements for damper sleeves within a wall opening are based on 1/8 inch per foot ( 10 mm per meter) of width or height unless otherwise stated in the listing of the assembly.
- 4) The sleeve (2) should be of suitable length to extend through the wall to enable the fitting of the cover angles and ductwork. Minimum of 90mm from the wall and total depth of the sleeve should not exceed more than 510mm.
- 5) The retaining angles (3) should be attached to the sleeve by 6 mm dia (4) bolts at a maximum of 110 mm centers, and should form a complete frame around the sleeve and cover over the expansion space (6) required between sleeve and wall opening. The four corner of the retaining angles are not to be welded. The bolts connecting the retaining angles to the sleeve to be 30 mm maximum from the corners. Retaining angles will be send in loose parts. Note: The retaining angles bolts should be out of the area of the damper frame.
- 6) The retaining angles (3) should be of such a size as always to form an overlap with the wall by 25mm minimum and should be manufactured from a minimum size of 35 x 35 x 1.5mm GI.
- 7) A fusible link –Elsle model-E rated 212°F used.
- 8) The duct sleeve connection to be of as per listed in UL 555. Connecting ducts shall not be continuous and shall terminate at the sleeve. Installation shall comply with NFPA 90A.
- 9) All fixing of frames must be positioned clear of the damper blade path so as not to impede proper closure.
- 10) Push the re-set button to reset the TRD (optional).

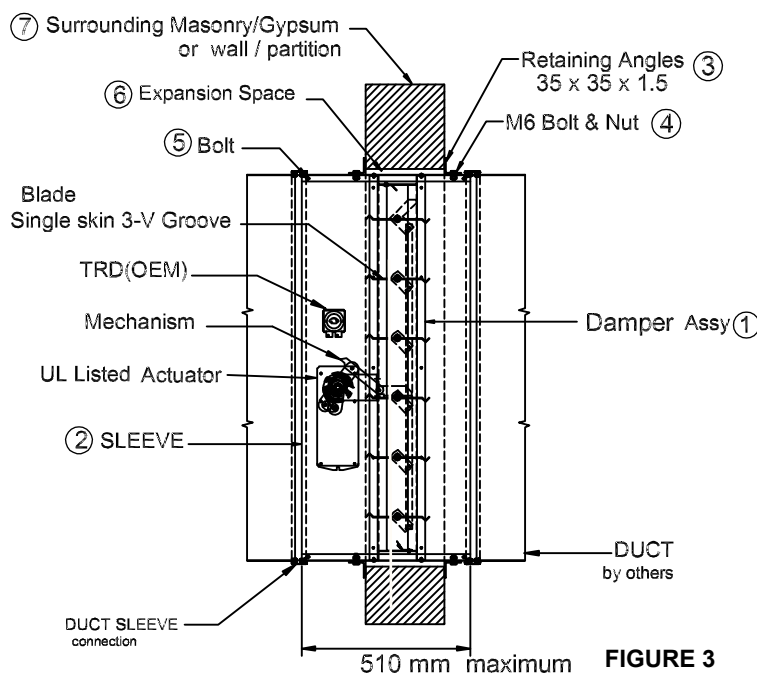

FIGURE 3





# MULTI-BLADE UL CLASSIFIED STATIC FIRE DAMPER MODEL BFD (3 HR) / MODEL BEFD (1½ HR)

## INSTALLATION

### (D) INSTALLATION AND OPERATING INSTRUCTIONS FOR MODELS BFD-F, BEFD-F, BFD/R-F & BEFD/R-F

- 1) The damper (1) should be installed vertical, centrally and resting on the bottom opening within the surrounding masonry / gypsum wall (7). Actuator should be out of wall / gypsum partition as shown in (figure 4).
- 2) The damper (1) should be installed in a rectangular galvanized steel sleeve (2) with a minimum thickness of 1.1mm. This sleeve should be attached to the damper using M6 bolts (5) and spaced at not more than 110 mm centers and 30 mm from corners.
- 3) Clearance requirements for damper sleeves within a wall opening are based on 1/8 inch per foot ( 10 mm per meter) of width or height unless otherwise stated in the listing of the assembly.
- 4) The sleeve (2) should be of suitable length to extend through the wall to enable the fitting of the cover angles and ductwork. Minimum of 90mm from the wall and total depth of the sleeve should not exceed more than 510mm.
- 5) The retaining angles (3) should be attached to the sleeve by 6 mm dia (4) bolts at a maximum of 110 mm centers, and should form a complete frame around the sleeve and cover over the expansion space (6) required between sleeve and wall opening. The four corner of the retaining angles are not to be welded. The bolts connecting the retaining angles to the sleeve to be 30 mm maximum from the corners. Retaining angles will be send in loose parts. Note: The retaining angles bolts should be out of the area of the damper frame.
- 6) The retaining angles (3) should be of such a size as always to form an overlap with the wall by 25mm minimum and should be manufactured from a minimum size of 35 x 35 x 1.5mm GI.
- 7) A fusible link –Elsle model-E rated at 165°F or 212°F used.
- 8) The duct sleeve connection to be of as per listed in UL 555. Connecting ducts shall not be continuous and shall terminate at the sleeve. Installation shall comply with NFPA 90A.
- 9) All fixing of frames must be positioned clear of the damper blade path so as not to Impede proper closure.
- 10) Lock the quadrant after adjusting the blade position / damper opening.

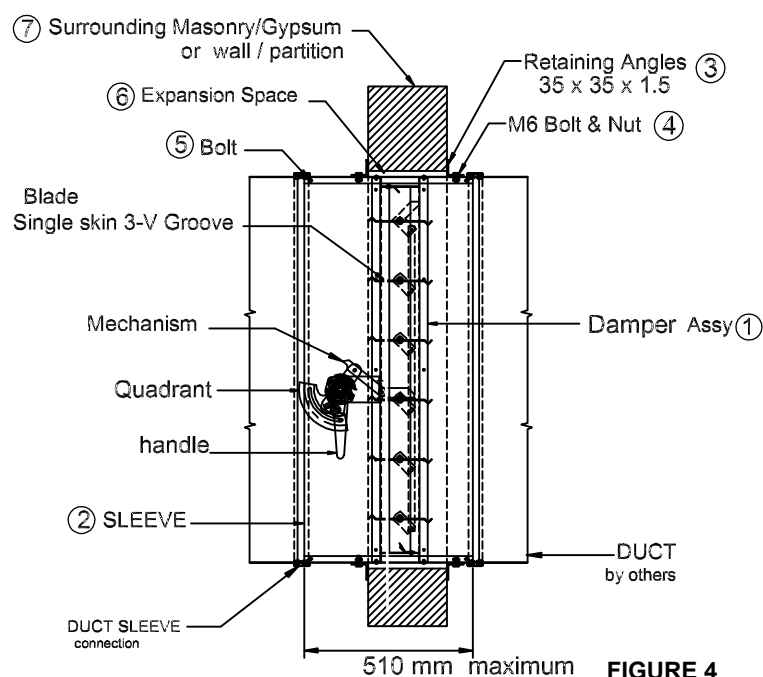



# MULTI-BLADE UL CLASSIFIED STATIC FIRE DAMPER MODEL BFD (3 HR) / MODEL BEFD (1½ HR)

## INSTALLATION

### EXPLODED ASSEMBLY WITH SLEEVE:

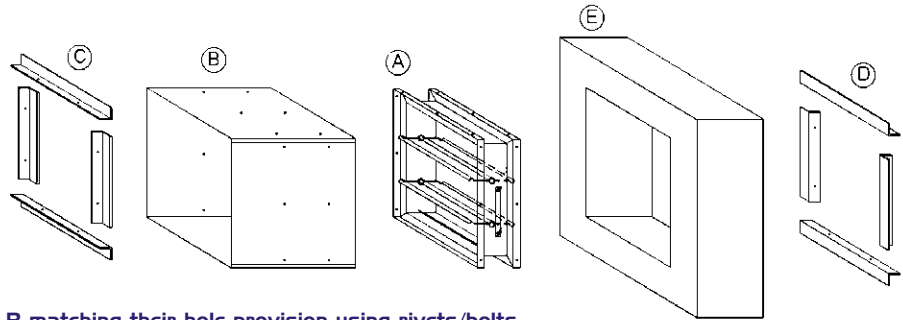

#### ASSEMBLY PROCEDURES:

- 1- Fix the damper A into the sleeve B matching their hole provision using rivets/bolts.
- 2- Fix the damper with sleeve into the concrete/gypsum wall opening E using the front retaining angle C 35X35 and matching their hole provision using M6 Hex bolt & nut. The sleeve B must overhang by a minimum of 90mm and maximum of 152mm. Opening size should have clearance of 3mm per 305mm of width and height.
- 3- Finally, when the subassembly is already fitted to the wall, fix the back retaining angle D 35X35 using M6 Hex bolt & nut.

## DUCT-SLEEVE CONNECTIONS

### FLANGED BREAKWAY CONNECTIONS:

TDC AND TDF ROLL-FORMED 4-BOLT FLANGED CONNECTIONS ASSEMBLED PER THE MANUFACTURER'S INSTRUCTIONS USING GASKETS, METAL CLEATS AND FOUR 9.5 mm METAL NUTS AND BOLTS.

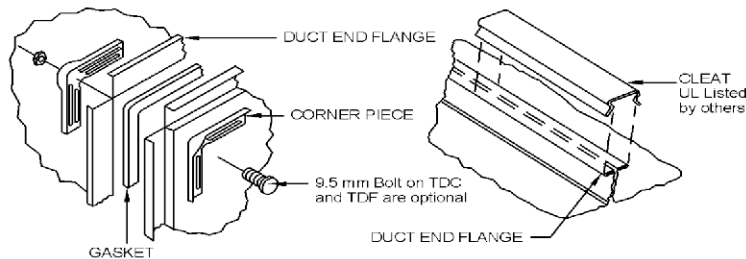

MANUFACTURED SLIP ON 4-BOLT FLANGED CONNECTIONS ASSEMBLED PER THE MANUFACTURER'S INSTRUCTIONS USING GASKETS AND PLASTIC CLEATS AS SHOWN BELOW.

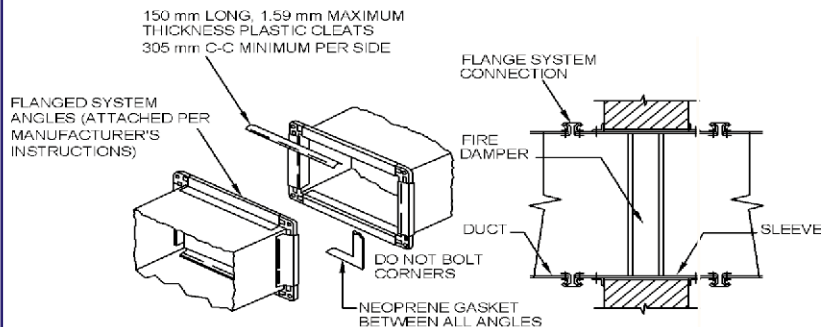

( UL TESTED CONNECTIONS BY OTHERS )

### TRANSVERSE JOINTS BREAKWAY CONNECTIONS (WITHOUT FLANGES):

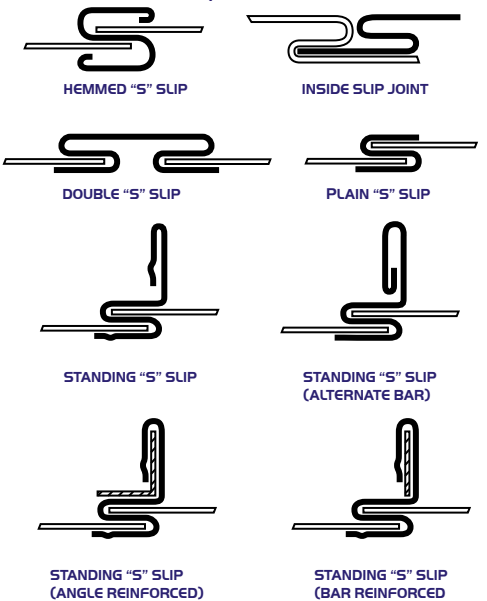

R21930





# MULTI-BLADE UL CLASSIFIED STATIC FIRE DAMPER MODEL BFD (3 HR) / MODEL BEFD (1½ HR)

## INSTALLATION / STEEL MULLIONS

### MANUFACTURING AND FIELD INSTALLATION INSTRUCTIONS FOR STEEL MULLIONS (as per SMACNA):

The mullions are used / necessary whenever the fire damper is installed into and opening that is larger than the largest UL rated size for the damper. The damper fire rated 1-1/2 hours.

Vertical, horizontal or vertical and horizontal mullions can be used depending on the area at the opening. The opening must not exceed 120" (inch) height, but it can be any width provided a vertical support mullion is used a maximum of every 120" (inch).

The mullions must be kept out of the air stream. For ducted system each subdivided opening (e.g. A x B) must be ducted individually.

The mullions are for using concrete block or poured walls only. The thickness of the wall is min, 177mm and max, 300mm.

### INSTALLATION

The END CAPS are attached to wall opening by means of 25mm long and 9mm Dia steel expansion anchor embedded with M6 list headed screws.

If a steel inlet are used then make welding 2 x 25mm long weld per length / each side of the mullions (eg. Before installing the End Caps make sure that they are inserted in the ends of the mullions).

### NOTES:

- (a) After installations of steel mullions refer installation page of the fire damper which is provided by the manufacturer.
- (b) Do not fastened retaining angle to the wall or steel mullions. The steel mullions must be free to float.

