



ADJUSTABLE RADIAL DEFLECTION TYPE - MODEL SW2

STANDARD CONSTRUCTION

- A radial array of adjustable black plastic cylindrical deflectors attached to slots into a square steel panel.
- With one counter sunk hole at the center for fixing.
- Powder coated to RAL 9010/9016.



APPLICATION

- For ceiling heights up to 4m.
- For high induction requirements (with VAV)
- For adjustable swirl air pattern.
- For Supply & Return air use.

DIMENSIONS

Model SW2

Size	mm				m ² A _{ef}
	∅D	□F	M	N	
300/8	300	298	248	248	0.009
400/16	400	398	348	348	0.019
500/16	500	498	448	448	0.019
600/16	600	598	548	548	0.019
625/16	625	623	573	573	0.019
500/24	500	498	448	448	0.028

Size	mm				m ² A _{ef}
	∅D	□F	M	N	
600/24	600	598	460	560	0.045
625/24	625	623	460	560	0.045
600/48	600	598	460	560	0.057
625/54	625	623	460	580	0.064
800/72	800	798	550	760	0.102
825/72	825	823	550	760	0.102

SW2-S4

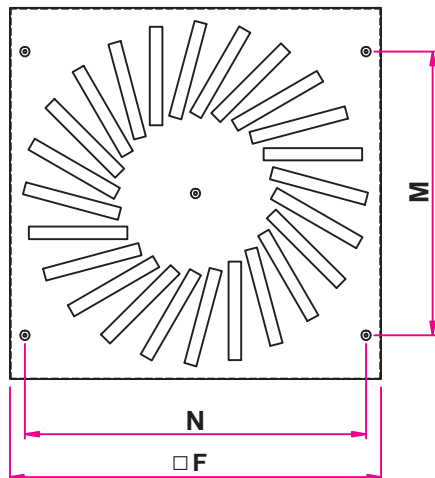

SW2-R

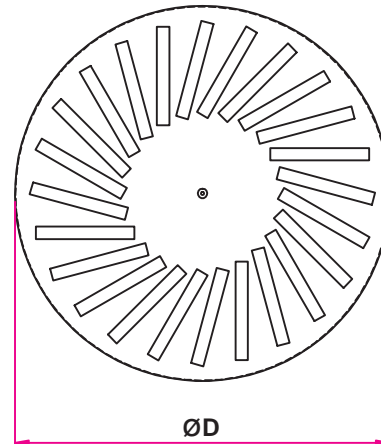



ADJUSTABLE RADIAL DEFLECTION TYPE - MODEL SW2

DIMENSIONS

SQUARE TYPE WITH PLENUM BOX & VCD AT SIDE SPIGOT: MODEL SW2SIPSV

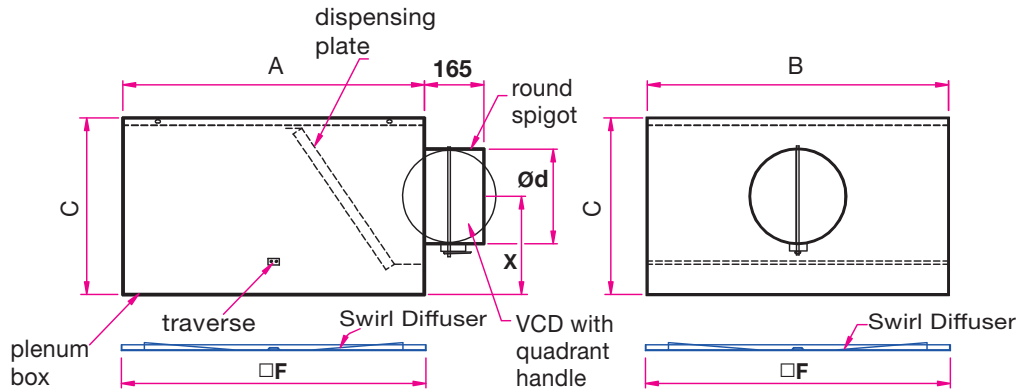

SQUARE TYPE WITH PLENUM BOX & VCD AT TOP SPIGOT: MODEL SW2SIPTV

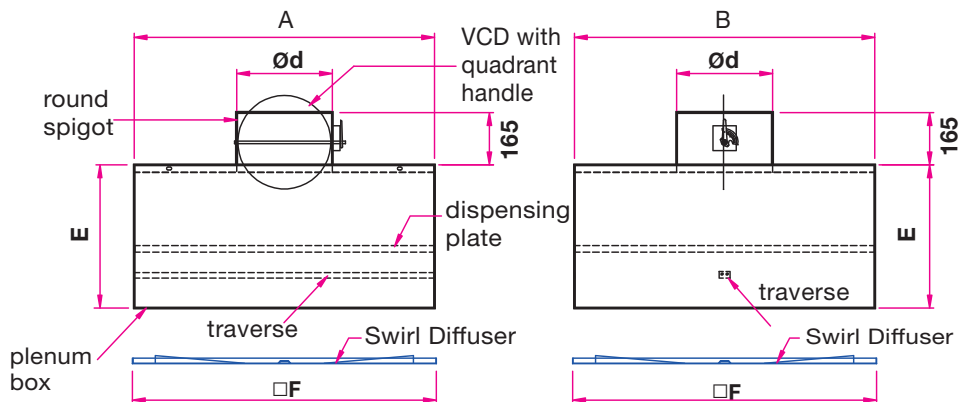

Size	mm						
	□F	A	B	C	X	E	Ød
300/8 S	298	325	325	240	137	200	158
400/16 S	398	390	390	290	167	240	198
500/16 S	498	390	390	290	167	240	198
600/16 S	598	390	390	290	167	240	198
625/16 S	623	390	390	290	167	240	198
500/24 S	498	390	390	290	167	240	198
600/24 S	598	590	590	325	177	240	248
625/24 S	623	590	590	325	177	240	248
600/48 S	598	590	590	325	177	240	248
625/54 S	623	590	590	325	177	240	248
800/72 S	798	790	790	450	250	300	313
825/72 S	823	790	790	450	250	300	313

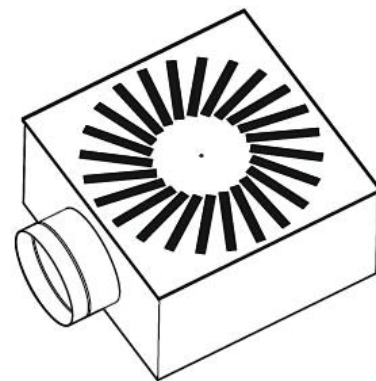



ADJUSTABLE RADIAL DEFLECTION TYPE - MODEL SW2

DIMENSIONS

ROUND TYPE WITH PLENUM BOX & VCD AT SIDE SPIGOT: MODEL SW2RPSV

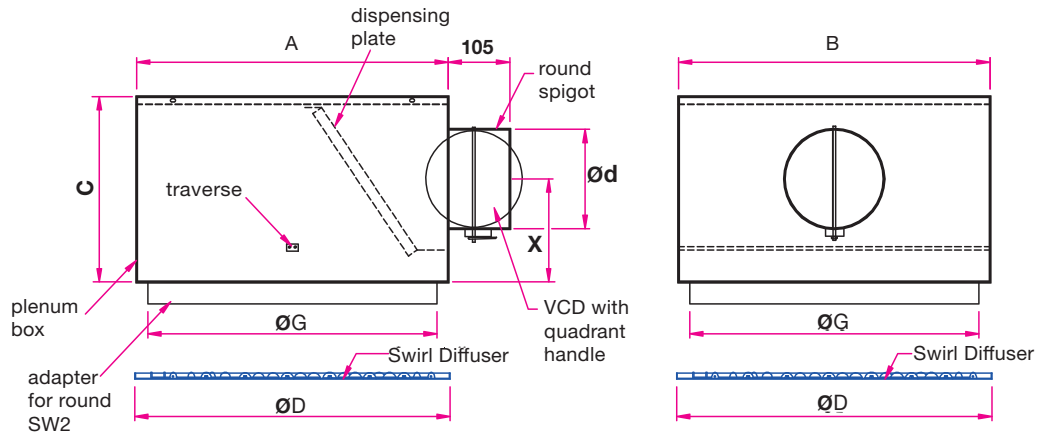

ROUND TYPE WITH PLENUM BOX & VCD AT TOP SPIGOT: MODEL SW2RPTV

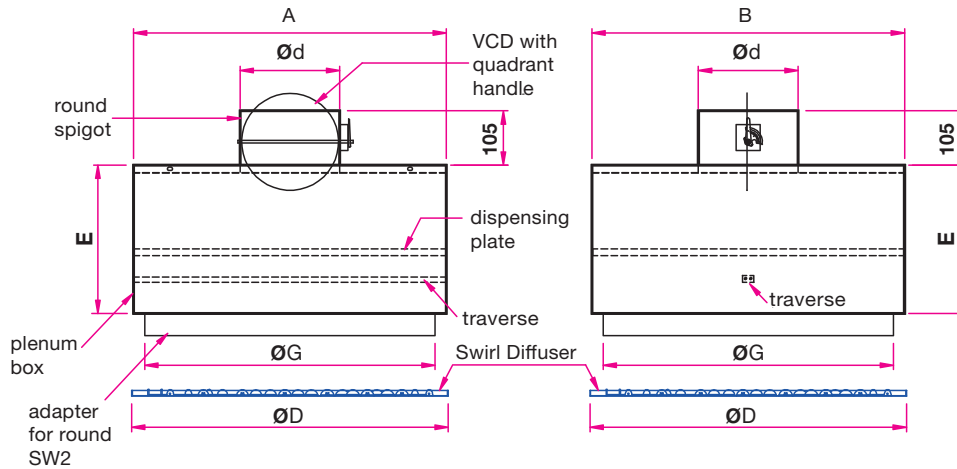

Size	mm							
	ØD	ØG	A	B	C	X	E	Ød
300/8 R	300	290	325	325	240	137	200	158
400/16 R	400	370	390	390	290	167	240	198
500/16 R	500	370	390	390	290	167	240	198
600/16 R	600	370	390	390	290	167	240	198
625/16 R	625	370	390	390	290	167	240	198
500/24 R	500	488	390	390	290	167	240	198
600/24 R	600	560	590	590	325	177	240	248
625/24 R	625	560	590	590	325	177	240	248
600/48 R	600	590	590	590	325	177	240	248
625/54 R	625	610	590	590	325	177	240	248
800/72 R	800	790	815	815	450	250	300	313
825/72 R	825	790	815	815	450	250	300	313





ADJUSTABLE RADIAL DEFLECTION TYPE - MODEL SW2

SIZES & DEFLECTORS ARRAY

SW2-S

SW2-R

300/8

300/8

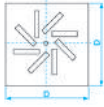

400/16. 500/16.
600/16 & 625/16

400/16. 500/16.
600/16 & 625/16

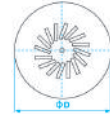
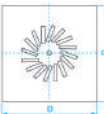

500/24

500/24

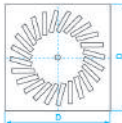

600/24 & 625/24

600/24 & 625/24

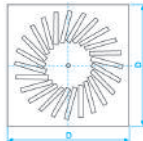

600/48

600/48

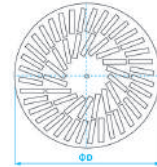
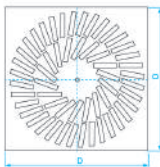

625/54

625/54

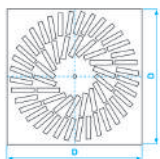

800/72 & 825/72

800/72 & 825/72

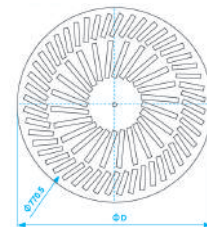
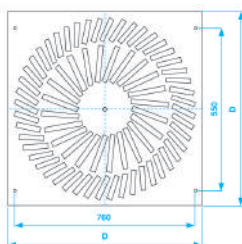



ADJUSTABLE RADIAL DEFLECTION TYPE - MODEL SW2

PERFORMANCE DATA

THROW:

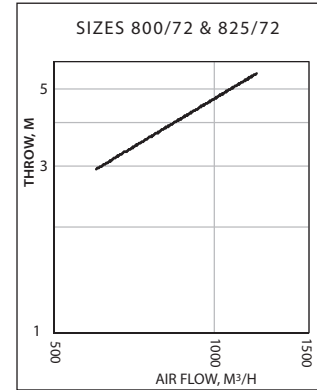
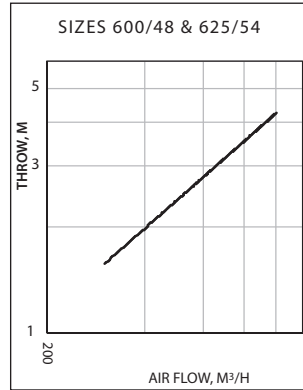
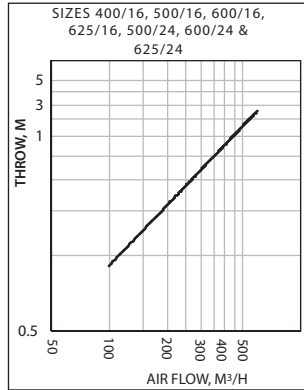
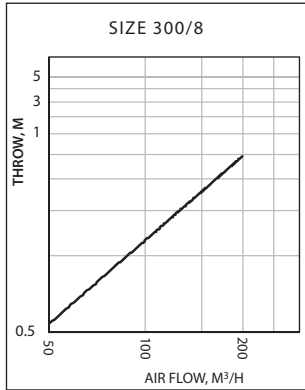

PRESSURE DROP:

